



CONCEPT SEATING

3120 & 3122

ASSEMBLY INSTRUCTIONS & OPERATING MANUAL



TOOLS NEEDED:

Two half-inch wrenches

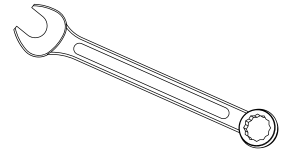
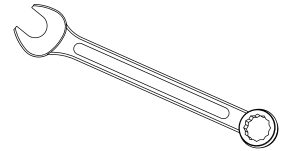

PARTS LIST

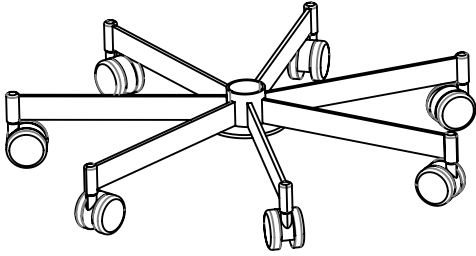

7-leg base with attached casters (1)



Gas cylinder (1)

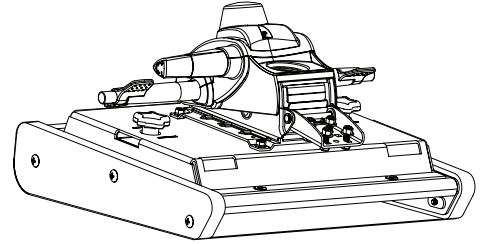

Seat Bottom (1)



Grease Packet (1)

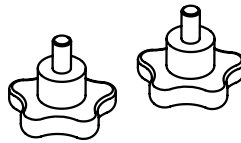

Handwheels (2)

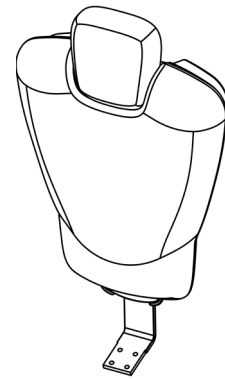

Seat Back (1)

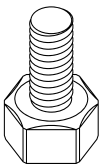

Bolts (4)

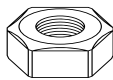

Nuts (4)



Washers (8)

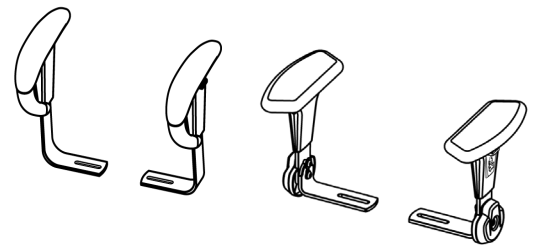

C-Loop OR Pivot Arm Rests (2)

Assembly Instructions

Assembling the Base

1. Open the base box, this is the smaller of the two boxes. Set the base of the floor.
2. Unwrap the cylinder from the plastic bag. Remove all packaging from the cylinder.
3. Open the grease packet, located in the cylinder bag, and place a line of grease around the cylinder, 2 inches from the bottom. NOTE: The top is the silver portion. The black portion is the bottom.



Place thin line of grease around the cylinder, 2 inches from the bottom.

Assembling the Base Cont.

4. Insert the bottom of the cylinder into the base.
5. Place another line of grease around the cylinder, approximately one-half inch from the top.

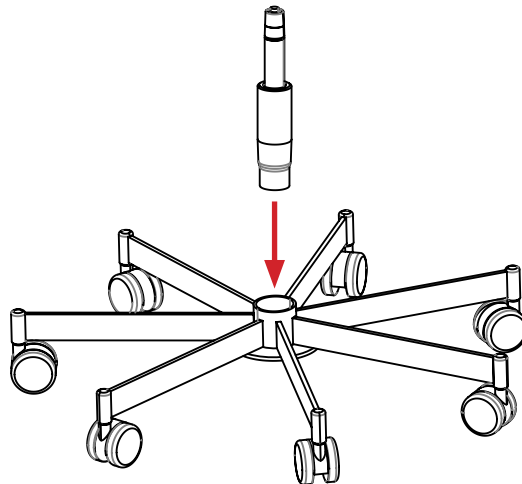

Assembly Instructions

Assemble the Seat

1. Open the chair box. This is the larger of the two boxes and may require a team lift. Take the seat back out of the box and remove the plastic bag. Locate the small red bag attached to the cardboard supports and set it aside. The red bag contains the hardware you will need for assembly.
2. Remove the cardboard filler. Take the seat bottom out of the box and remove the plastic bag.

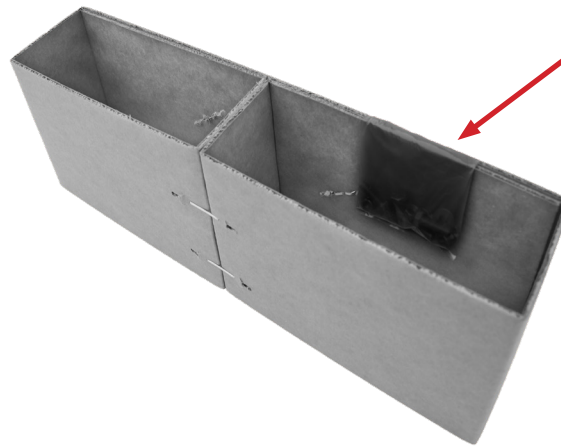

Assemble the Seat Cont.

3. Place the seat bottom on the floor with the cushion side down. The U-channel should face towards you.
4. With the seat back cushion side down, slide the J-bar into the seat bottom U-channel. You may need to prop both sections up so the J-bar slides in easily.

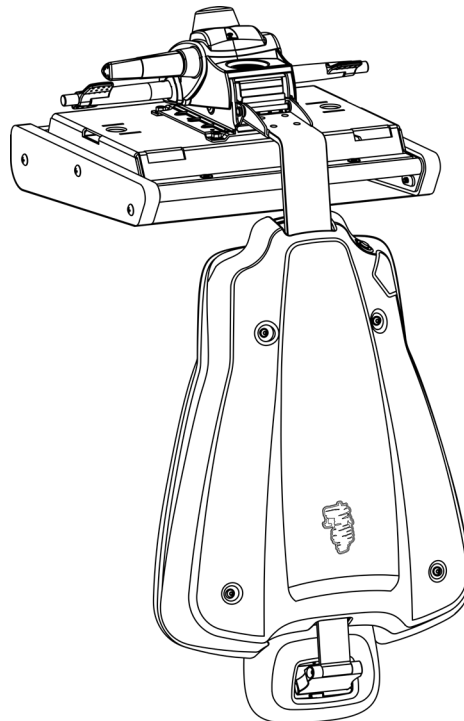

Assembly Instructions

Assemble the Seat Cont.

5. Line up the four holes. Place one washer on the bolt head side and thread through the pre-machined hole. Then, place an additional washer and nut on the opposite side of the bolt head.
6. Use one half-inch wrench to hold the bolt in place. Then use the second half-inch wrench to tighten the bolt. Repeat steps 5 and 6 until all four bolts are secured.

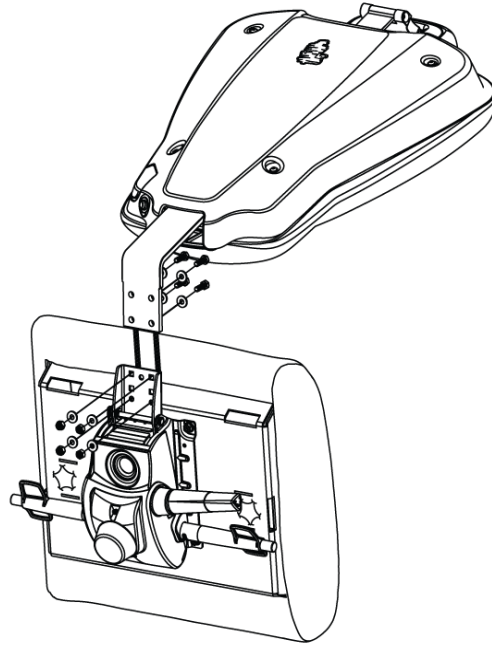

*We recommend tightening the top two holes first for ease of assembly.

Assemble the Seat Cont.

7. Unscrew the two handwheels. These are located on the bottom of the seat, both left and right sides. Set handwheels aside for later use.

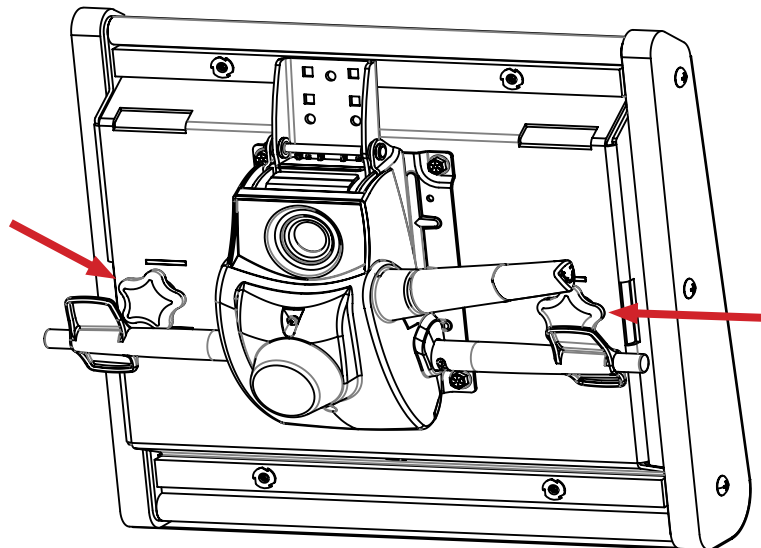

Assembly Instructions

Assemble the Seat Cont.

- Next, slide the cylinder with attached base into the machined hole of the tilt mechanism. The cylinder fits into the tilt mechanism as a compression fit. No additional assembly is required.
- Bring the chair upright.

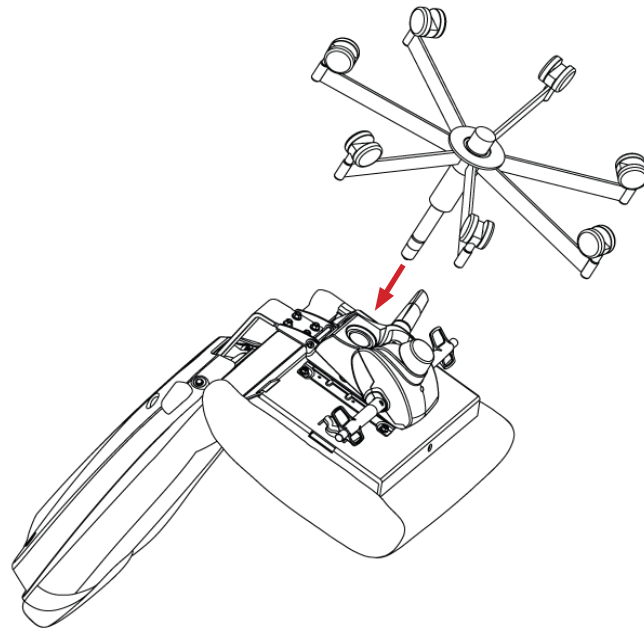

Attach the Armrest to the Chair

- Open the arm rest box. This is located in the chair box.
- Slide arm rest into the machined arm rest slot. Repeat for other side of chair. For C-loop arms, the closed section should go to the front of the chair. Pivot arms are universal and may be placed on either side of chair.

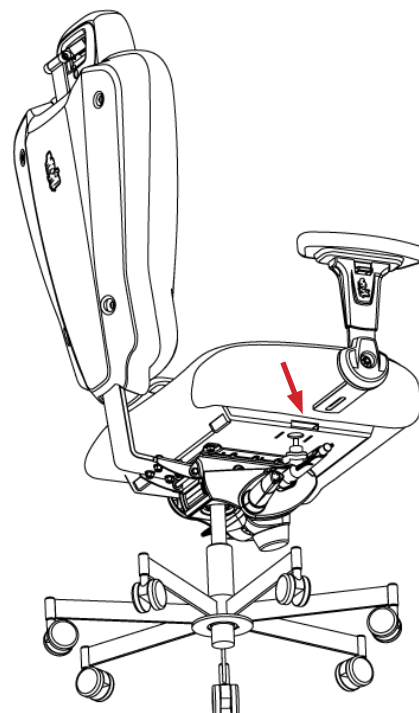

Assembly Instructions

Attach the Armrests to the Chair

4. Screw the handwheels in until snug. Do not over tighten. If the handwheel screws in crooked, stop. Remove the handwheel and start over. This will prevent cross threading.
5. Sit in the chair and make sure all the adjustments work properly.

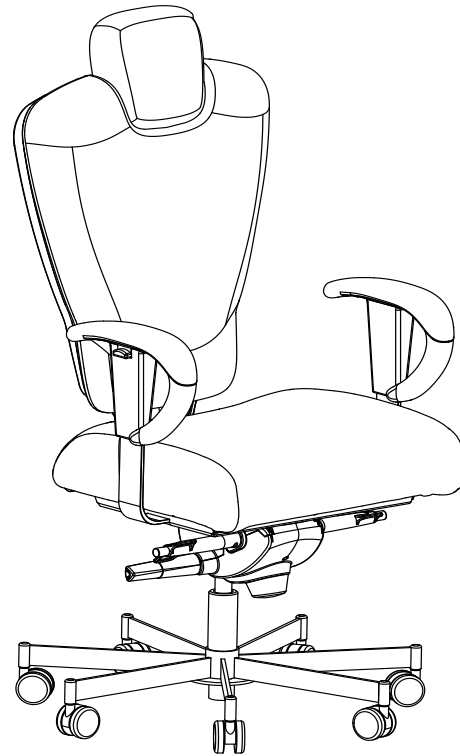

Care for Your Chair



Need more information on your new chair?

Scan the QR code to visit our maintenance and repair directory. Here you'll find video content and more tools on how to properly use and care for your new Concept Seating chair.

For further assistance, please contact us at info@conceptseating.com.

Adjustment Guide

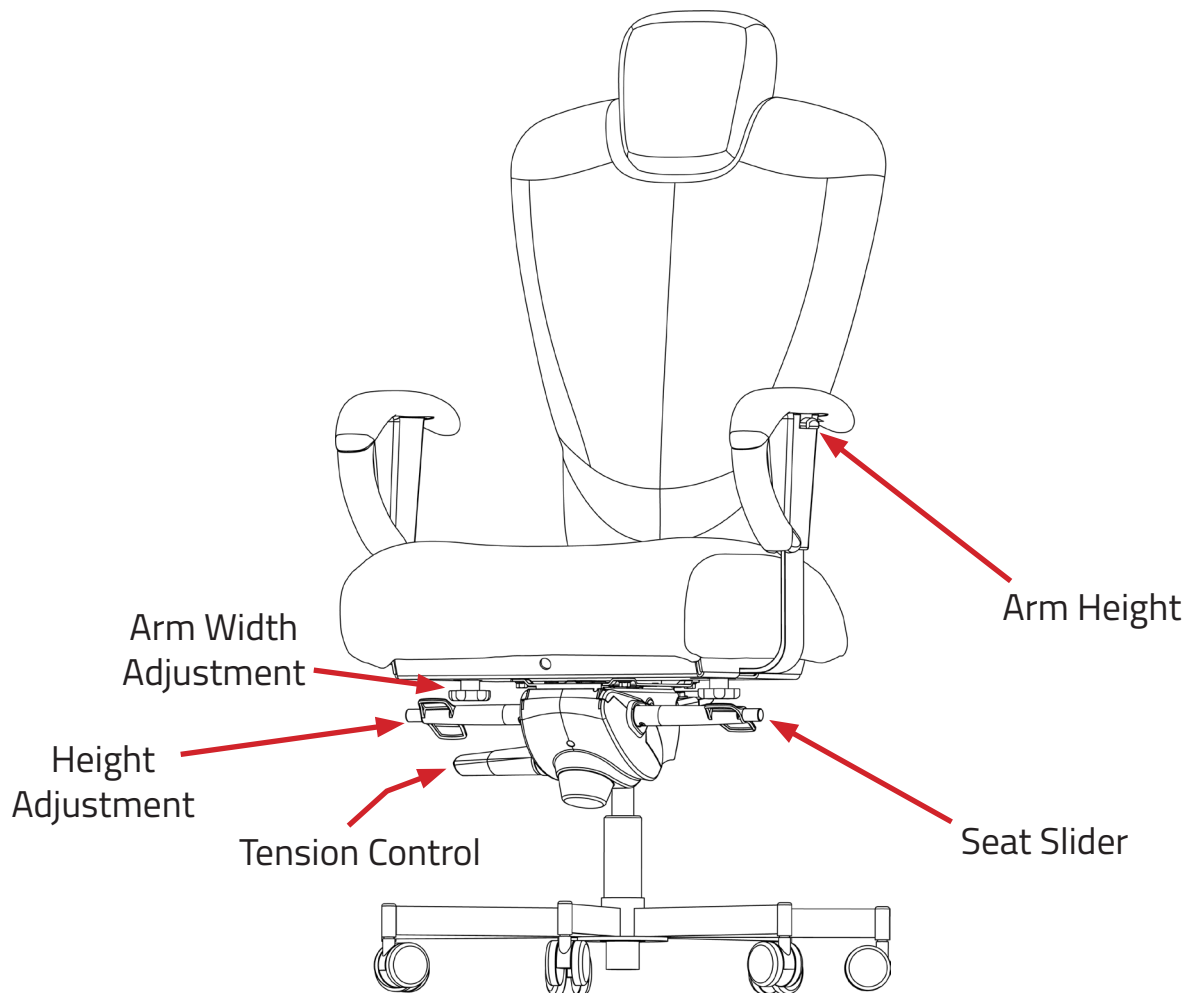

- **Height Adjustment/Seat Position Lock:** Twist the paddle to adjust the height up or down. To move down, use your body weight to lower the chair. To move up, stand up and let the chair raise. Press the button to lock it back in place; press again to unlock.
- **Tension Control:** This feature adjusts the amount of force needed to adjust the backrest. Twist clockwise to increase the strength of tension for your chair. Twist counterclockwise to decrease the tension.
- **Seat Slider:** Twist the paddle to adjust the seat bottom, forward to backward.
- **Arm Height:** To adjust the height of the armrest, locate the button underneath the armrest pad. Push the button in to raise or lower the arm. Button location is the same for both C-loop and pivot arms.
- **C-Loop Arm Pad:** With your hand, you may move the arm pad forward or backward and left or right.
- **Arm Width Adjustment:** Turn the handwheel clockwise to loosen. Pull out the arm rest to desired width. Turn the handwheel counterclockwise to tighten and secure the armrest in place. Adjust for both right and left sides.

Adjustment Guide Cont.

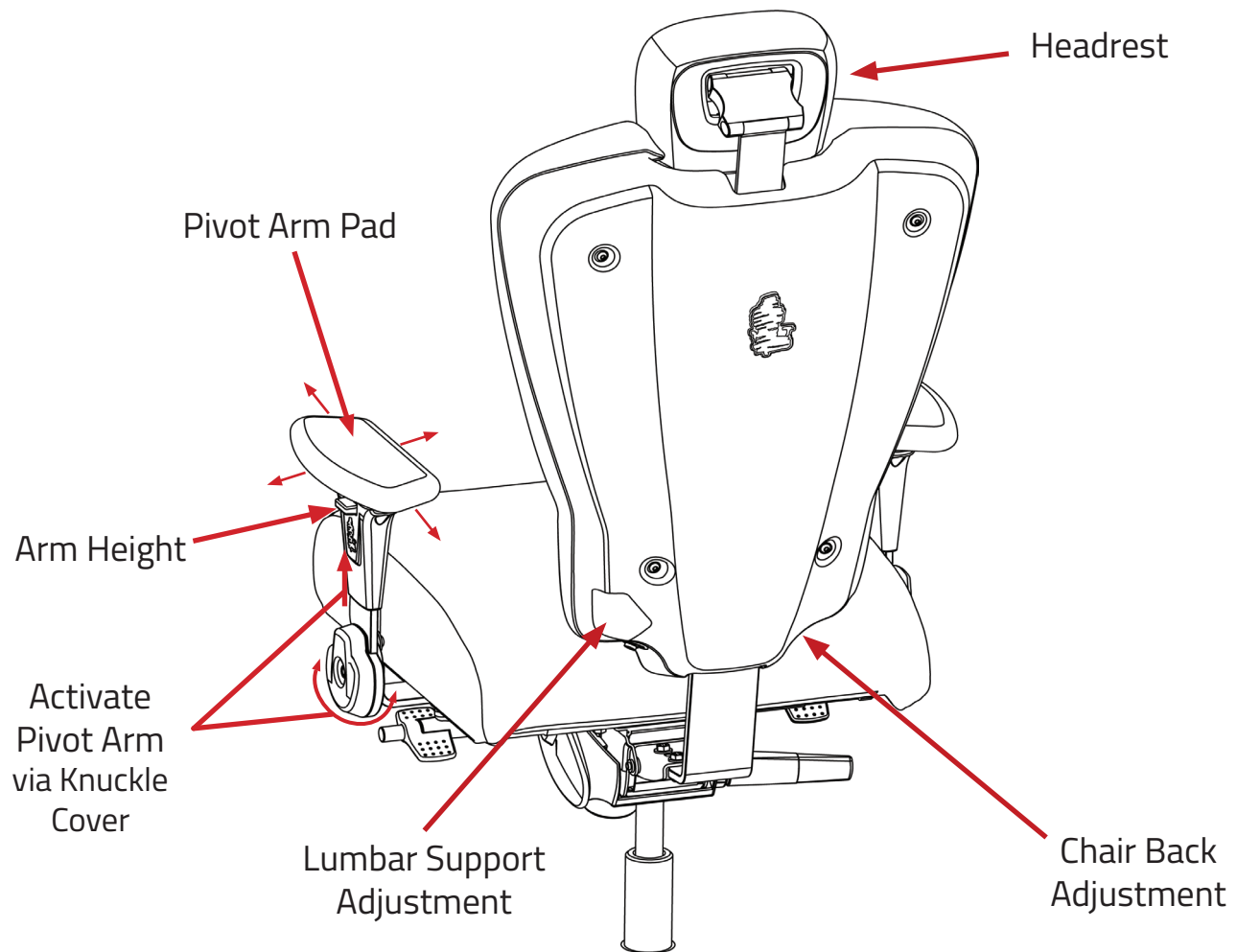

- **Lumbar Support Adjustment:** Press large button to inflate the lumbar support adjustment until you reach desired support. To deflate, locate small button underneath and press.
- **Chair Back Adjustment:** Place hands on the bottom of chair back and lift up to the desired position. There are five ratchet positions. The sixth ratchet position will return it to the bottom.
- **Headrest:** Angle headrest cushion to the desired location either as a headrest, neckroll, or move it out of the way. To adjust the height, lift the headrest up. There are five ratchet positions. The sixth ratchet position will return it to the bottom.
- **Pivot Arm Pad:** With your hand, move the arm pad forward or backward and left or right.
- **Activate Pivot Arm:** Holding the knuckle cover, raise pivot arm until the arm releases from the bracket. Pivot the arm front or back to the desired location.

Cleaning Guide

Always pre-test any cleaning method in an inconspicuous or unexposed area. We recommend purchasing a slipcover if sharing chair with others.

Alternative Leather

For basic maintenance, clean the whole surface in circular motions using liquid hand soap and water (1 part soap to 9 parts water). Rinse and wipe with a clean damp white cloth to get rid of any excess soap. Repeat as needed and then let dry.

To disinfect with a bleach solution, use 0.5% concentration, which can be prepared as one part bleach per 10 parts of water. Rinse and wipe with a clean, damp, white cloth to get rid of any excess. Allow the chair to dry thoroughly.

DO NOT USE: Solvents like paint thinner, Varsol®, acetone, whiteners, waxes, silicones, detergents, and/or cleaning products that are not pH neutral. Abrasive cleaning tools such as plastic or wire sponges or hard-bristle brushes can permanently damage alternative leather. Never use alcohol.

Leather

For black leather, dust with a clean, dry cloth for routine cleaning. For spots and spills, wipe excess liquid immediately and let air dry. If necessary, use lukewarm water and mild soap, work into a thin lather with a soft cloth, rinse with clean water, and buff to restore luster. A leather cleaner or conditioner may also be used.

For all other colors, dust with a clean, dry cloth for routine cleaning. Wipe the leather with a clean, damp cloth to remove soil and allow it to air dry. Leather conditioners and protectants, such as those by Leather Master® can be used as directed. Should a spill occur, blot immediately using a clean cloth or paper towel. For a more thorough cleaning, a solution of lukewarm water and a mild cleaner, such as Ivory® soap or Woolite®, may be used. Dampen a clean white cloth and gently wipe the affected area using a circular motion. Rinse completely with a clean cloth to ensure all cleaner is removed. Dry with a paper towel or dry cloth and allow to completely air dry. Repeat the cleaning process as needed, allowing the leather to dry between applications.

DO NOT USE: Bleach, ammonia, or any harsh cleaners. These types of cleaners eat away at leather and the dye.

Cleaning Guide Cont.

Fabric

Vacuum the chair. Next use an upholstery brush and spot treat to remove stains. Fill a handheld steam cleaner with water and steam your fabric chair. You can use detergents with some steam cleaners; this will help remove strong odors. Allow the chair to dry thoroughly. Spray the seat with a fabric refresher to complete the deodorizing process.

DO NOT oversaturate the surface with water or other cleaning solutions. This can cause mold and foul odors. Avoid excessive scrubbing as this will set in stains.

Cordura

Soil may be removed with spray cleaner or detergent and water. Oil or grease should first be treated with a dry cleaning solvent followed by a spray cleaner or detergent and water.

DO NOT USE: Chlorine or bleach based cleansers.

ESD Fabric

Clean with water-based cleanser or mild dry cleaning solvent.

DO NOT USE: Products containing bleach. Never use heat. Heat can set stains. Do not saturate the surface with water or other cleaning solutions. Soak up any excess moisture immediately.

Casters

First, pull out any large clumps of hair or dirt that are lodged in the wheel. Vacuum the casters using the appropriate attachment or blow out any dirt with compressed air. When the casters are clean, you may use a lubricant, such as WD40®, to ensure wheels move as smoothly as possible. Clean once every six months.



CONCEPT SEATING

Division of Laacke & Joys Company, LLC



24/7 Intensive Use Seating Warranty Policy

Laacke and Joys Company LLC warrants, to the original purchaser of Concept Seating 24/7 seating products, that the steel seat frame shall be free from product failure under normal 24/7 use for a period of 10 years from the original date of manufacture, with the exception of model 3156, for which the steel seat frame will be warranted for a period of 6 years from the date of manufacture.

All other components of the Concept Seating 24/7 Intensive Use chairs are warranted against product failure (as defined solely by Laacke and Joys Company LLC; see exceptions below) for a period of 6 years from the original date of manufacture. All warranty claims will be remedied via the method which is most appropriate for each individual situation as determined solely by Laacke and Joys Company LLC.

The warranty further covers:

- The steel foot ring and 200mm cylinder on the Concept Seating 24/7 stool model is warranted for 2 years. This does not apply to the Two-Step Stool models, which are fully covered for 6 years.
- Shipping costs for parts replaced under warranty will be paid by Laacke and Joys Company LLC for the first 2 years of the warranty term, with the customer responsible for all shipping costs after the first 2 years.

Examples of what the warranty does not cover:

- Abuse, alteration, misuse, or negligence of the chair or its components at the sole discretion of Laacke and Joys Company LLC.
- Failure to follow the manufacturer's assembly, operating and/or preventative maintenance instructions, either by purchaser or third-party
- Use of models 3142, 3142r1, 3120, 3122, 3150HR, or 3152HR by persons weighing over 550 pounds, or the use of model 3156HR by persons weighing more than 800 pounds
- Products exposed to extreme environmental conditions such as water, smoke, excessive humidity, corrosive materials or improper storage (products should be stored in a dry, climate controlled environment.)
- Products sold by unauthorized dealers.
- Minor variations of color in cover materials against sample swatches or previous purchases.
- Minor irregularities of color, surface, grain, texture, wrinkles or stretch marks in natural leather.
- Fading or discoloration over time or due to soiling, staining, or dye-transferring from clothing.
- Labor costs associated with the installation of warranted parts.
- Any damage not noted on the freight bill before signing at time of delivery

In no event shall the total liability of manufacturer resulting from product failure, as damages or otherwise, exceed the purchase price of the product. Neither Laacke and Joys Company LLC nor their authorized dealers under any circumstances shall assume responsibility for loss of time, inconvenience, commercial loss, expenses for travel, lodging, or damage to personal property, loss of revenue, or incidental or consequential damages.

Laacke and Joys Company LLC reserves the right to make changes or improvements in the design of Concept Seating products without obligation to make corresponding changes or improvements in previously manufactured Concept Seating products.

All warranty claims must be submitted using the online claim form at www.conceptseating.com/warranty-claim.

This is the exclusive and complete warranty made by Laacke and Joys Company LLC with respect to the Concept Seating 24/7 Intensive Use seating products. No person whatsoever is authorized to make any representation, warranty, or promise on behalf of the manufacturer. Laacke and Joys Company LLC makes no other expressed warranties and disclaims any and all implied warranties. The remedies set forth above pertaining to repair or replacement of parts or materials are exclusive of all other remedies. Dealer makes no warranty on his or her own.

800.860.9896

CONCEPTSEATING.COM

3120/22 Install Instructions
Form # CS1064 • Rev 1 • 03/06/2023